

ELECTRO-PROPORTIONAL VALVES—FLOW CONTROLS

PV70-30 Proportional Flow Control Cartridge,

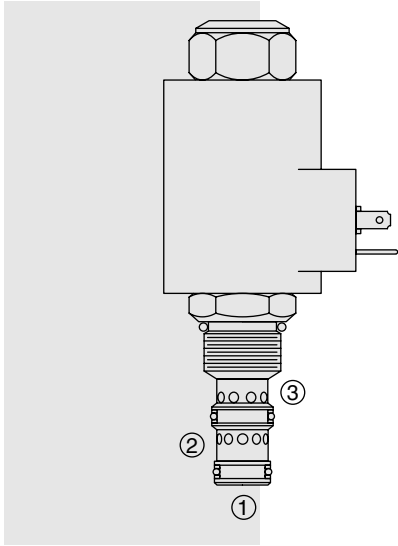

DESCRIPTION

A solenoid-operated, electrically-variable, three-port, pressure-compensated, spool-type, normally closed when de-energized, proportional flow control valve. It can be used as a priority-type flow regulator with pressure-compensated, regulated and bypass flow. It can also be used as a restrictive-type 2-way, pressure-compensated flow regulator when the bypass line (port ②) is blocked.

OPERATION

The PV70-30 will regulate flow out of port ③ regardless of system working pressure. With an increasing current applied to the solenoid, the PV70-30 will increase output flow.

Note: When used as a bypass flow control in applications where the priority flow port will be blocked by external valving, bypass pressure drop will increase unless a small amount of leakage is provided for the priority port. Consult factory.

Operation of Manual Override:

To Engage: Turn clockwise approximately 1 turn to reach start point. Continue another approximately 5 turns to full shift.

To Disengage: Turn counterclockwise approximately 6 turns to positive stop.

FEATURES

- Excellent linearity and hysteresis characteristics.
- Hardened spool and cage for long life.
- Optional coil voltages and terminations.
- Efficient wet armature construction.
- Cartridges voltage interchangeable.
- Unitized, molded coil design.
- Coil waterproofing standard.
- Manual override option.

RATINGS

Operating Pressure: Inlet: 240 bar (3500 psi); Ports ② and ③: 207 bar (3000 psi)

Regulated Flow Rate: Bypass Blocked, Range A: 26 lpm (7 gpm)
Bypass Blocked, Range B: 17 lpm (4.5 gpm)
Bypass Open, Range A: 30 lpm (8 gpm)
Bypass Open, Range B: 17 lpm (4.5 gpm)

Maximum Input Flow: Bypass Open, Range A: 50 lpm (13 gpm)
Bypass Open, Range B: 26 lpm (7 gpm)

Internal Leakage: 197 cc/min. (12 cu. in./min.) fully closed at 207 bar (3000 psi)

Electrical: 2 standard voltage ratings

Coil Voltage	Resistance @ 20°C	Threshold Current	Max. Control Current
12 VDC	4.7 ohms	350 ± 70 mA	1500 ± 200 mA
24 VDC	19.0 ohms	175 ± 35 mA	750 ± 100 mA

Filtration: See page 9.010.1

Fluids: Mineral-based or synthetics with lubricating properties at viscosities of 7.4 to 420 cSt (50 to 2000 ssu)

Installation: No restrictions; See page 9.020.1.

Cavity: VC10-3; See page 9.110.1

Cavity Tool: CT10-3X-XX; See page 8.600.1

Seal Kit: SK10-3X-MM; See page 8.650.1

SYMBOLS

USASI/ISO:

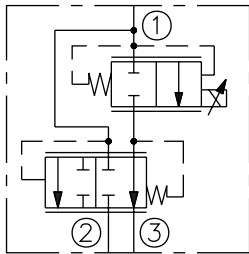

PERFORMANCE

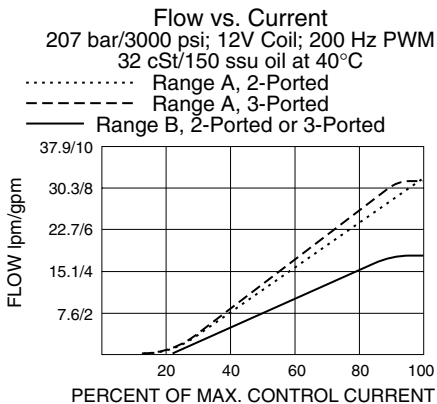

Performance info. continued on following page.

Recommended Controllers (See Section 3)

Input Sig. w/12V Coil	DIN Coil Mount	PCB Board	Metal Box	DIN Rail Mount
0-5 VDC	7114950	4000046	4000049	4000136
0-10 VDC	4000070	4000141	4000124	4000137
4-20 mA	4000123	4000143	4000130	4000139
PWM	—	4000144	4000133	4000140
w/24V Coil				
0-5 VDC	4000161	4000194	4000174	4000136
0-10 VDC	4000165	4000141	4000182	4000137
4-20 mA	4000169	4000143	4000186	4000139
PWM	—	4000144	4000133	4000140

Normally Closed

PV70-30

PERFORMANCE (Continued)

Regulated Flow vs. Pressure Drop
2-Ported; Flow Range A
240 bar/3500 psi Inlet
12V Coil; 200 Hz PWM
32 cSt/150 ssu oil at 40°C

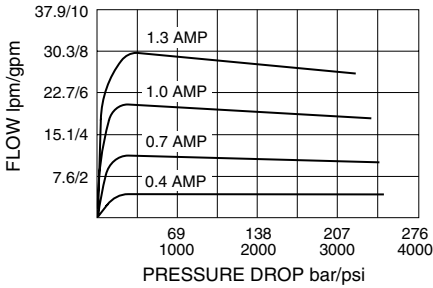

Regulated Flow vs. Pressure Drop
2-Ported; Flow Range B
240 bar/3500 psi Inlet
12V Coil; 200 Hz PWM
32 cSt/150 ssu oil at 40°C

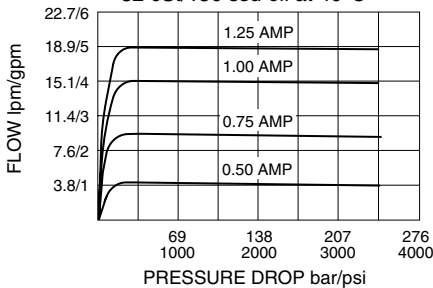

DIMENSIONS

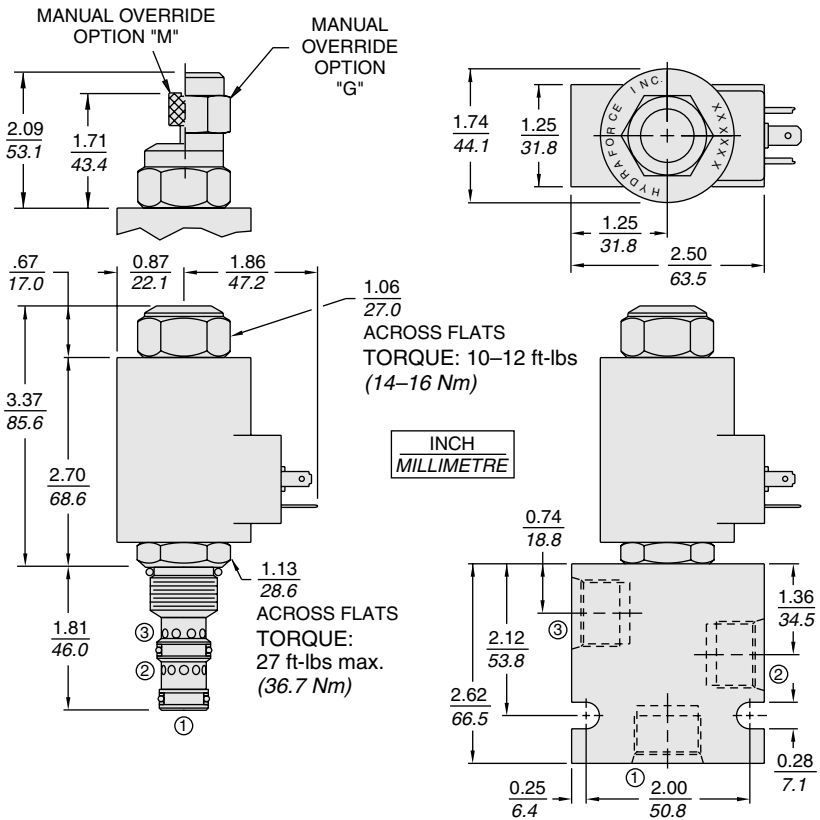

MATERIALS

Cartridge: Weight: 0.19 kg. (0.42 lbs.); Steel with hardened work surfaces. Zinc-plated exposed surfaces. Buna N O-rings and polyester elastomer back-ups standard.

Standard Ported Body: Weight: 0.36 kg. (0.80 lbs.); Anodized high-strength 6061 T6 aluminum alloy, rated to 240 bar (3500 psi); See page 8.010.1. Steel and Ductile Iron bodies available; consult factory.

PV70 Series Coil: Weight: 0.32 kg. (0.7 lbs.); Unitized thermoplastic encapsulated, Class H high temperature magnet-wire; See page 3.270.1.

TO ORDER

